

9 2
9 3 10 1
10 3

: Clemson University Design Department of Automotive Engineering

:

: Dr. Zoran Filipi

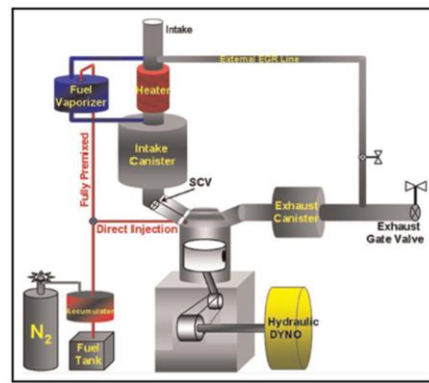
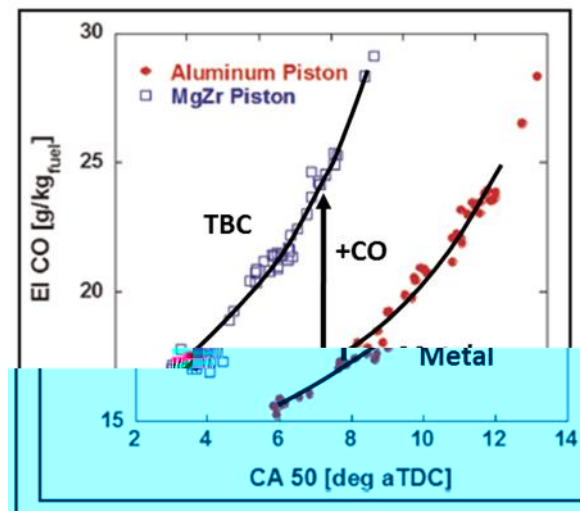
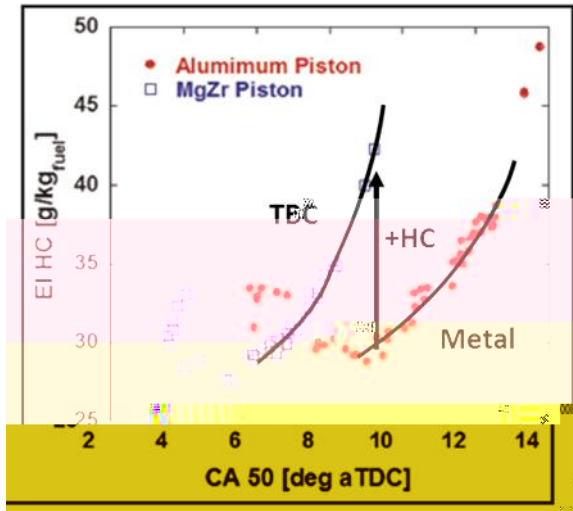

$$P(T, Z) = P_{foc} \left[\frac{1}{T - T_{foc}} \right] \ln \left(\frac{RVP - P_{foc}}{P_{foc}} \right)$$

$$T_{RIP} = A(Z - Z_{RIP})$$

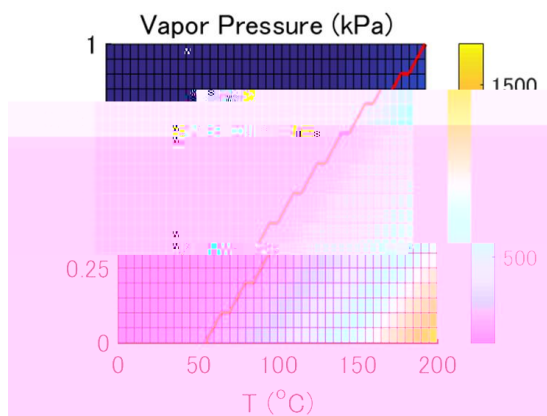
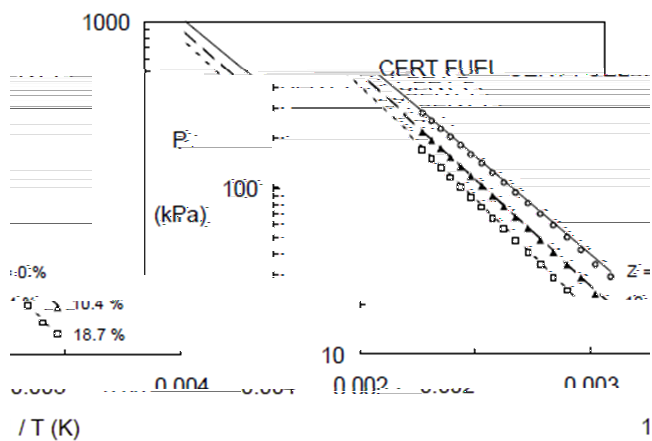

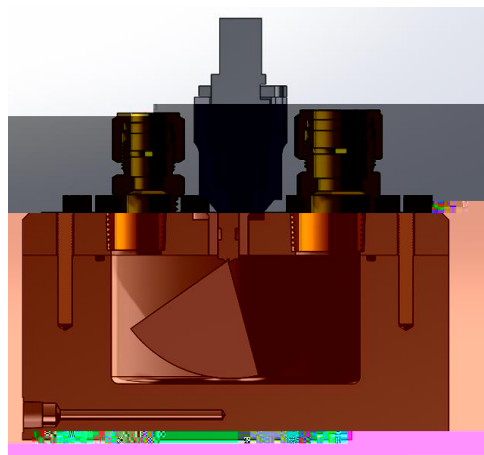
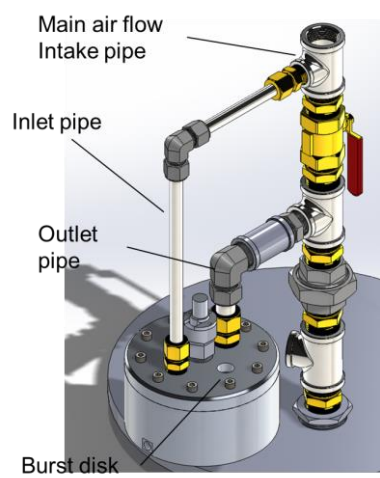

Zoran FILIPI