

---

---

THAI KOBELCO WELDING CO., LTD.

1.

TKW THAI KOBELCO WELDING CO., LTD. , 1968 , 50

TKW 2

2

TKW THAI KOBELCO WELDING CO., LTD.

1968

302

3

8 19 8 21 ( )

8 22 8 23 ( )

8 24 ( )

8 25 9 6

9 4

9 8 ( )

9 9 9 10 ( )

9 11 9 13 ( )

4

1

, 5

. 5 , 25

,  
,

.  
.

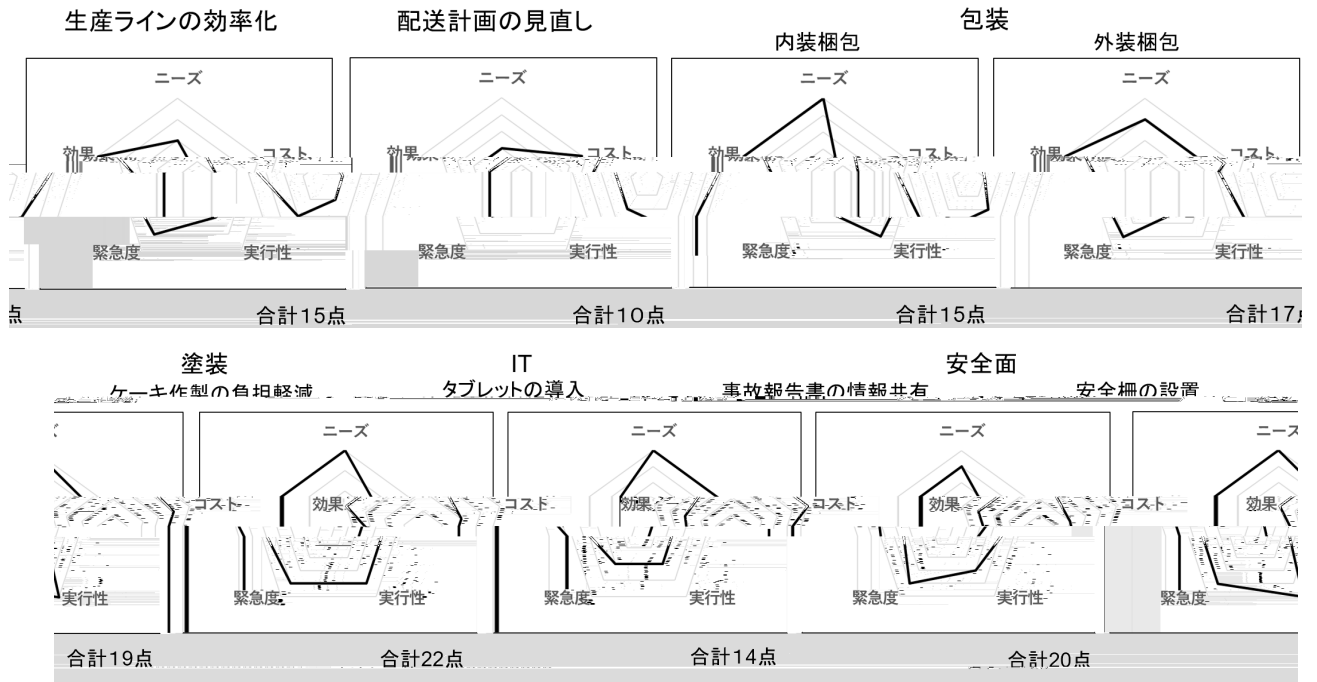

1

5

5.1

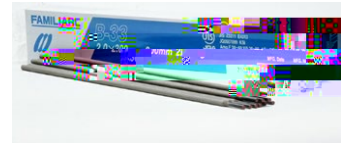

2

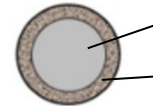

3

TKW

10 15

5.2

5.2.1

4

1.

2.

3.

4

5.

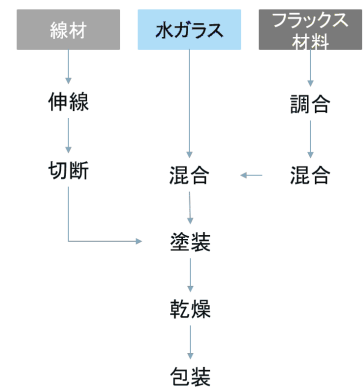

4

5.2.2

5.2.3

1

2

3

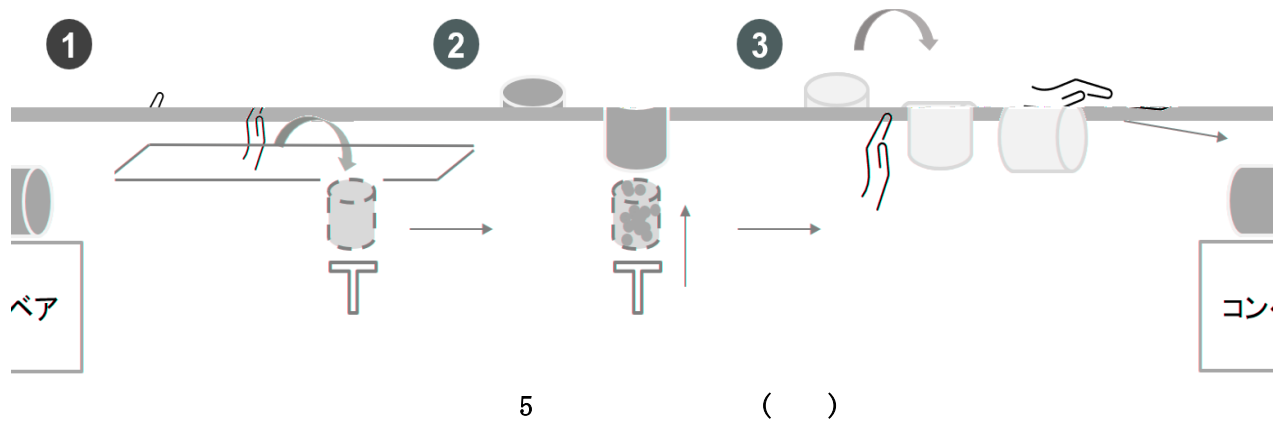

5.3

5.3.1

6

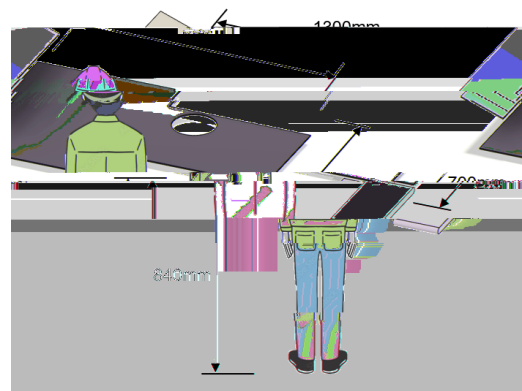

, 1 1

5 10

6

TKW

5.3.2

( 5- ) , ( 5- )  
 ( 5- )  
 ( 5- ) , 7  
 5  
 8

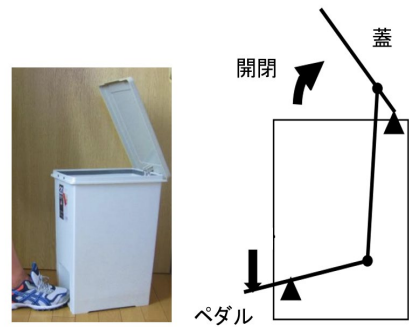

7

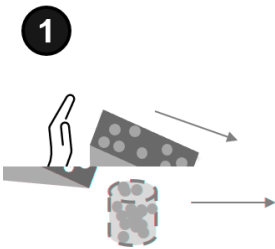

1

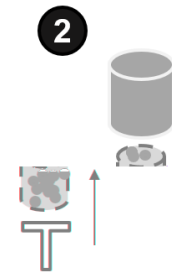

2

8

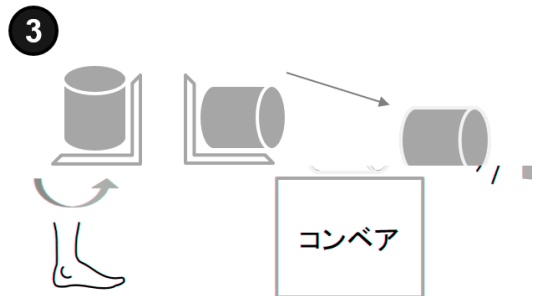

3

( )

5.3.3 ( )  
 9

90

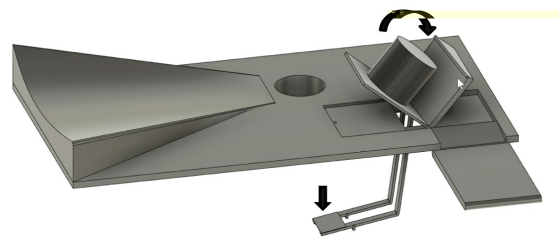

9

( )

5.3.4 ( )  
 TKW

1

10

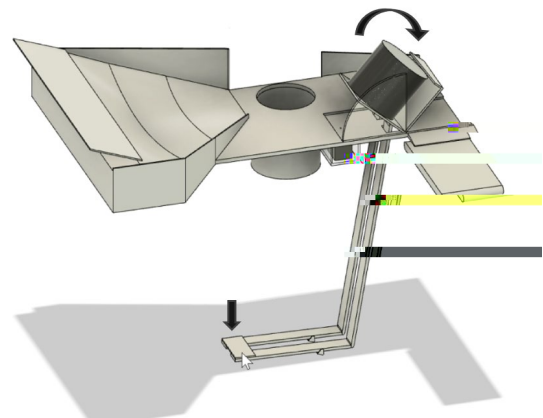

10

( )

---

,

,

.

,

.

UHMW ( )

,

.

,

( 11 )

5.5

( 5- ) , ( 5- ) ,  
 14 15 ( 5- ) .  
 , ,  
 16 17 ( 5- )  
 , ,

1.丸みを帯びた傾斜



2.可変式傾斜



3.手動ベルトコンベア



14 ( )

	コスト	作業者負荷	清潔性
1.丸みを帯びた傾斜	◎	▲	◎
2.可変式傾斜	▲	◎	◎
3.手動ベルトコンベア	▲	◎	▲

15 ( )

1. 足の力

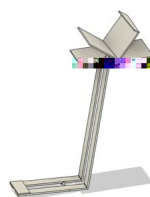

2. シリンダー

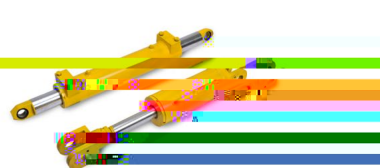

16 ( )

	コスト	作業者負荷	清潔性
1. 足の力	◎	◎	▲
2. シリンダー	◎	◎	▲

17 ( )

