

PRESS RELEASE

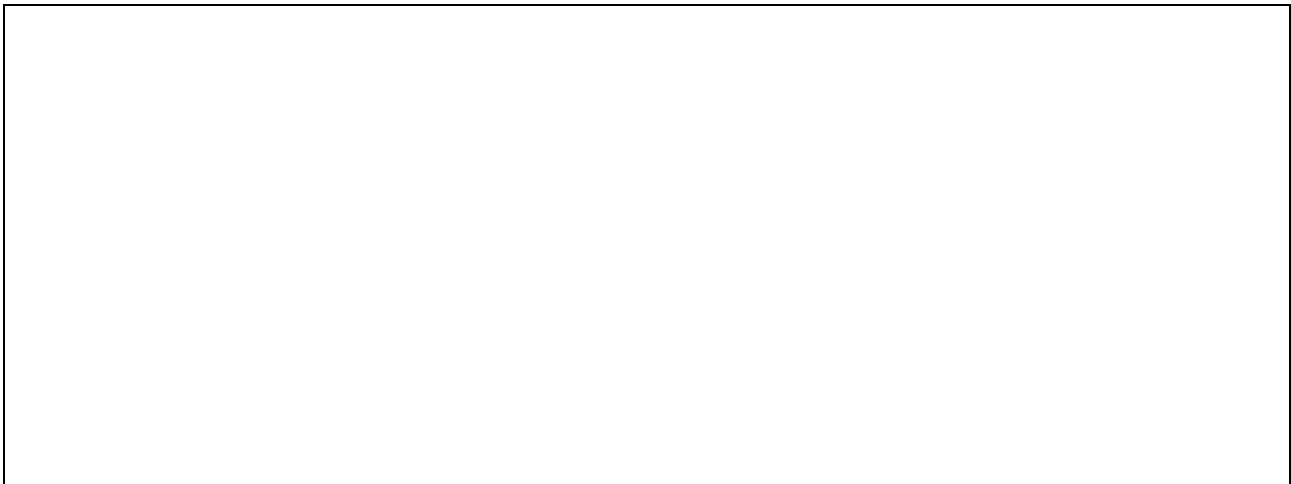

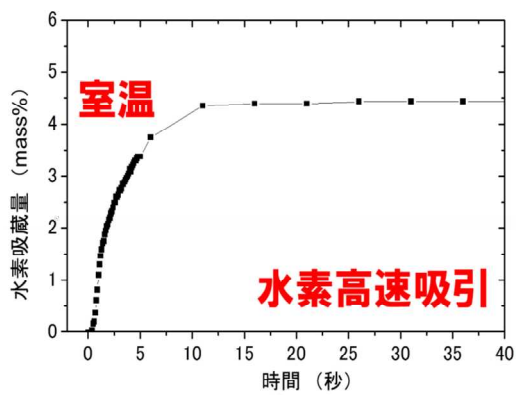



受

爆発の危険性がある空間内の水素捕集と高純度水素の輸送・供給

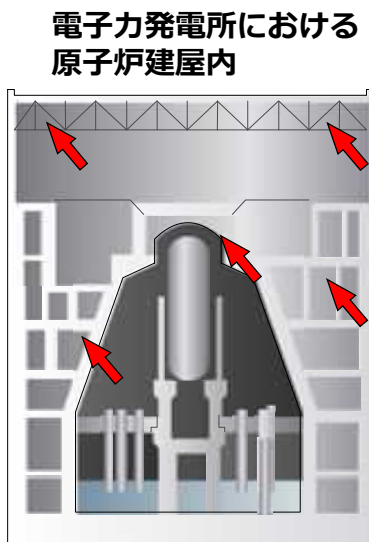

燃料電池自動車



水素ステーション

