(カイベトナム有限責任会社 (ベトナム)) 研修報告書

1. 半自動射出成型機における製品と不要部の分離

2. 倣い研削盤におけるカムの設計

工学研究科 機械システム工学専攻 藤原 丈一朗

□

5

35~40cm

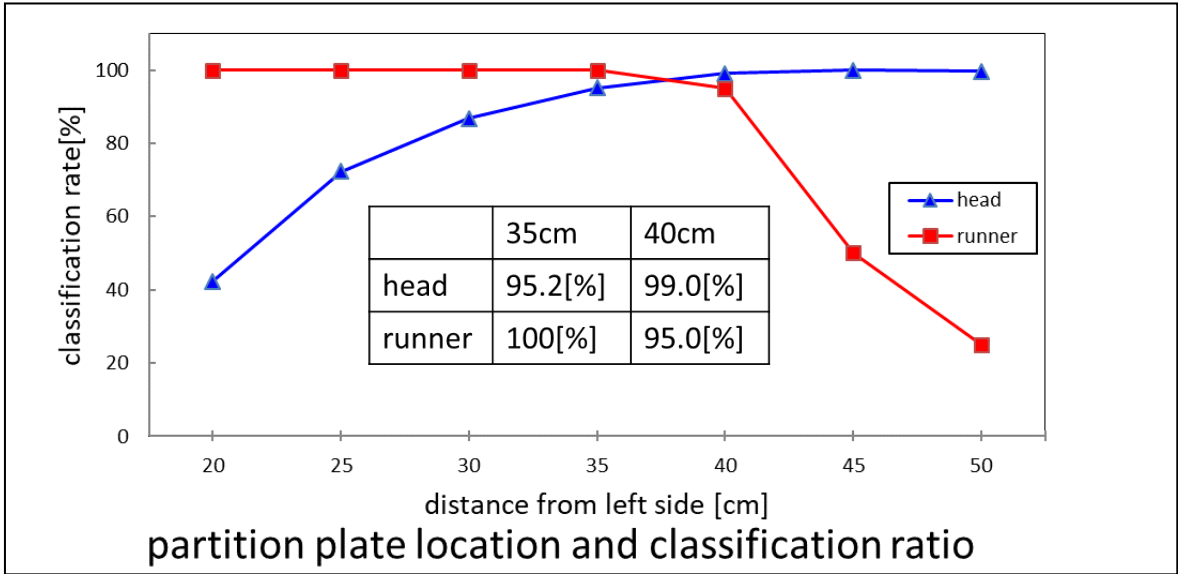

7.

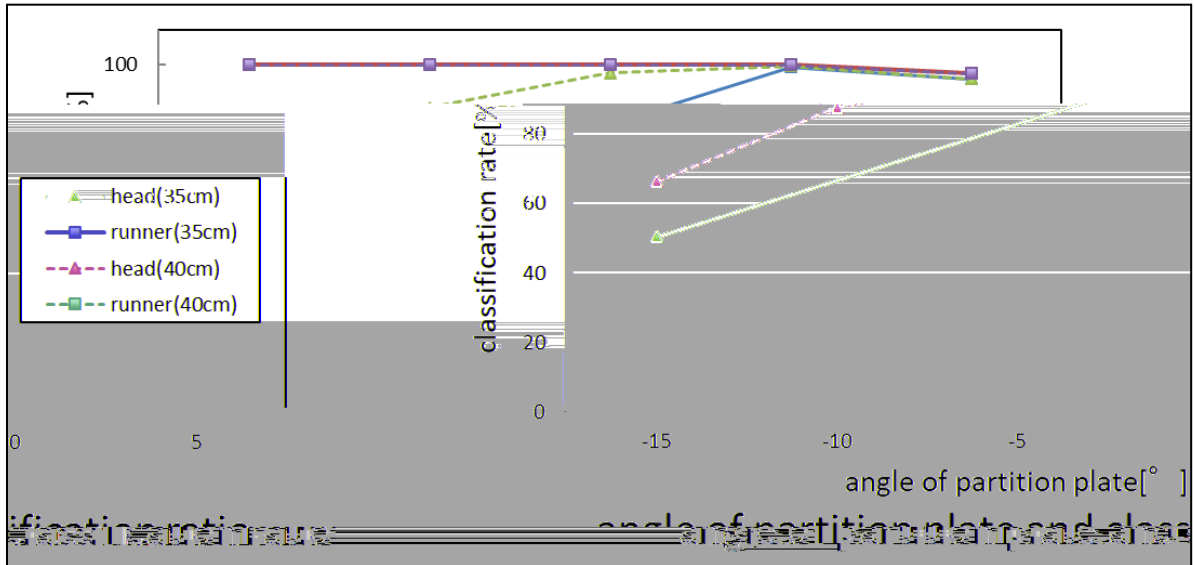

8.

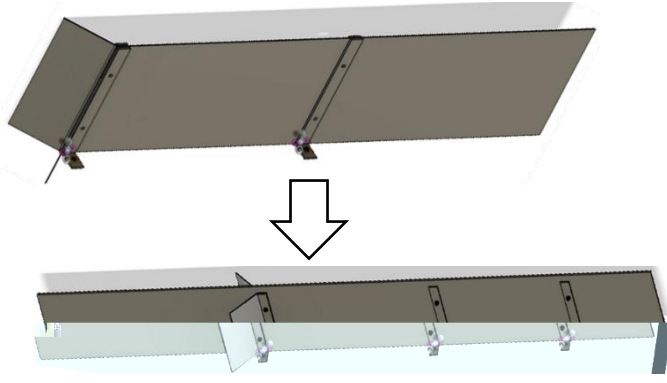

9.



10.

1.

	35cm	40cm
head	97.5[%]	99.0[%]
runner	96.5[%]	86.5[%]

2.

	35cm	40cm
head	98.5[%]	99.4[%]
runner	100[%]	99[%]

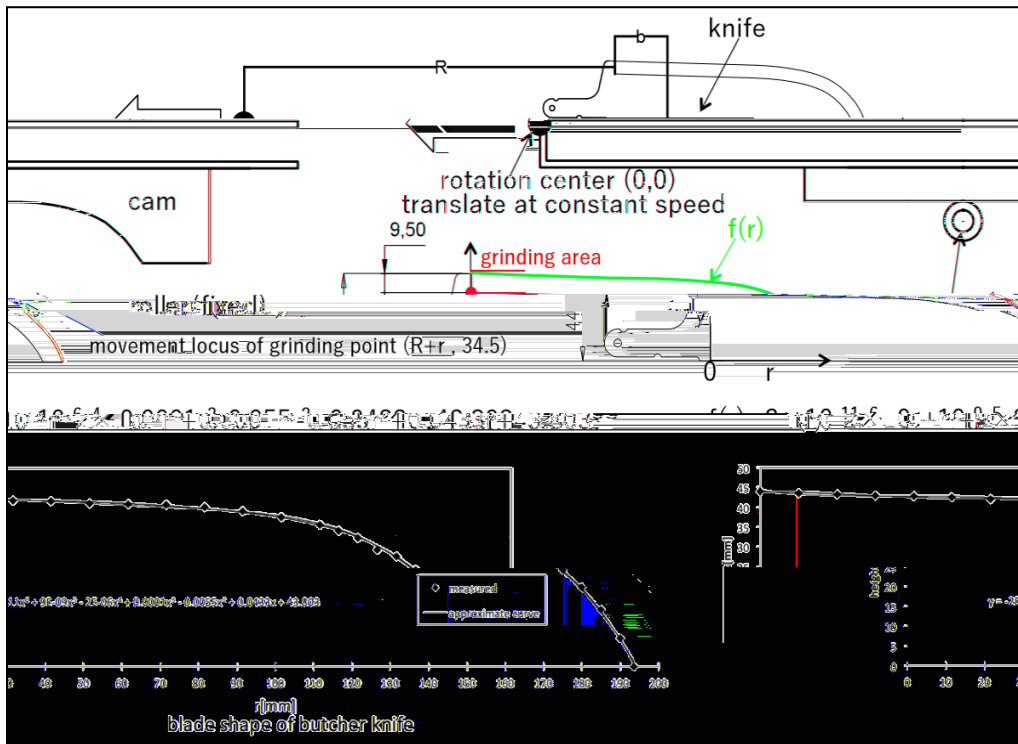
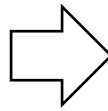

11.

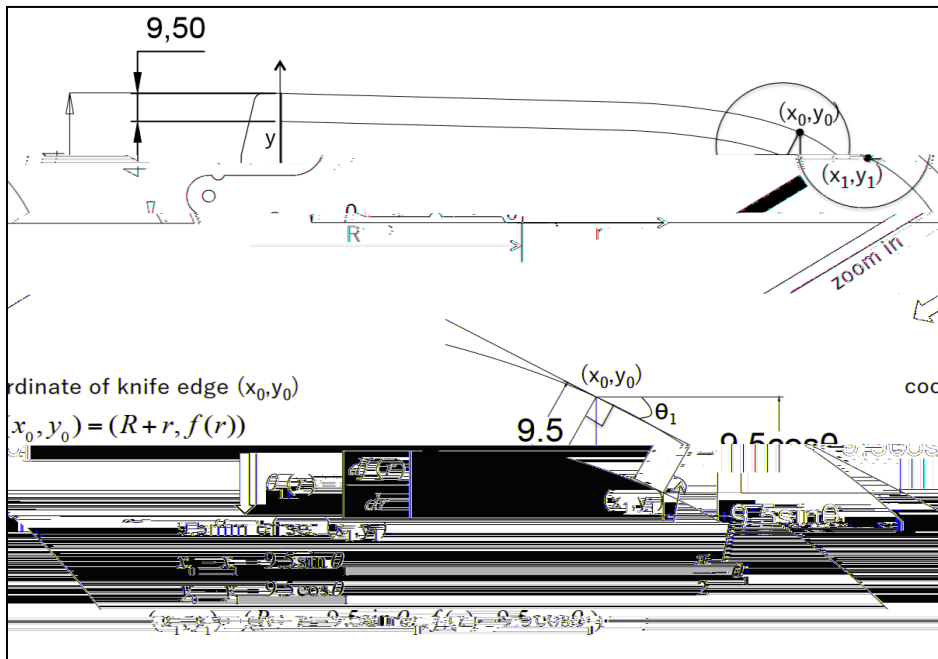

12. (x_0, y_0) (x_1, y_1)

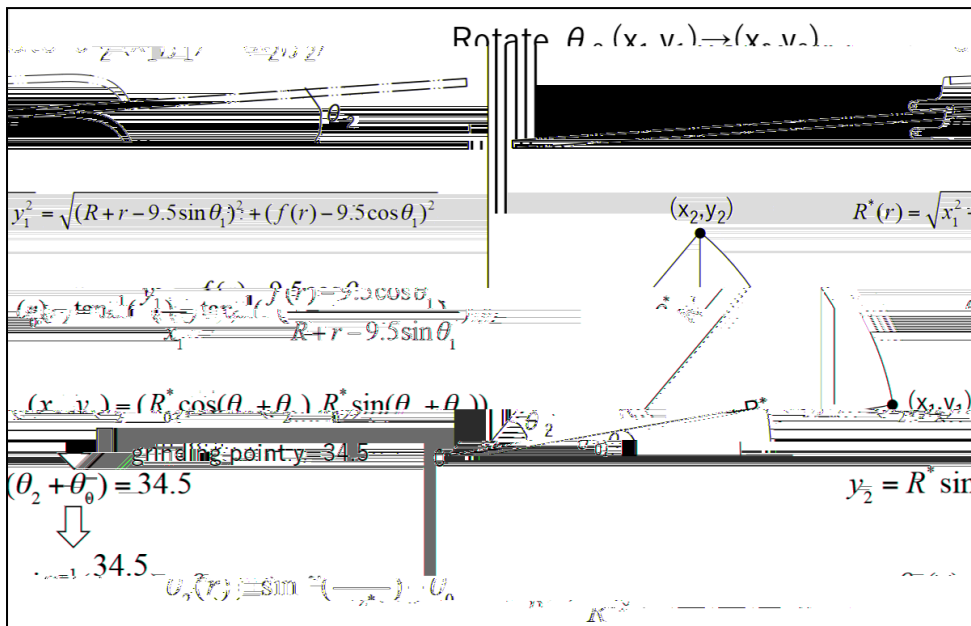

13.

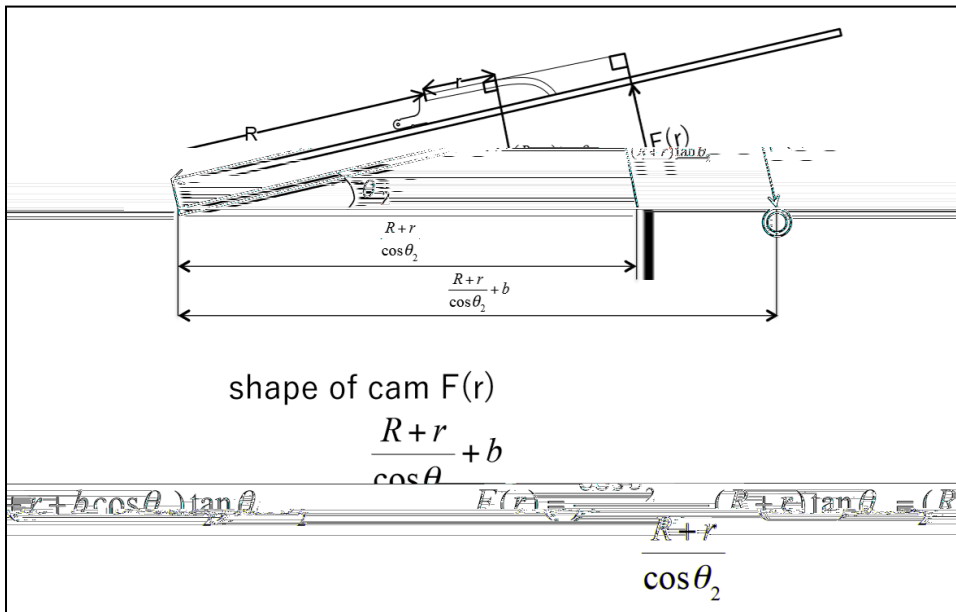

14.

$F(r)$

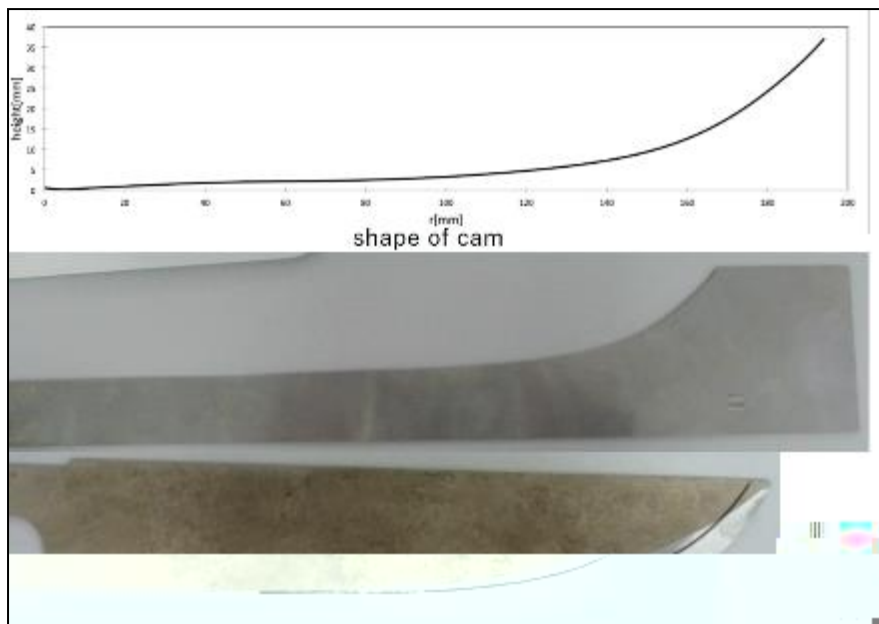

15.

7.

8.

Thuan

Vinh

ECBO

ECBO
